

SPC-P-2

EXPLODED VIEW

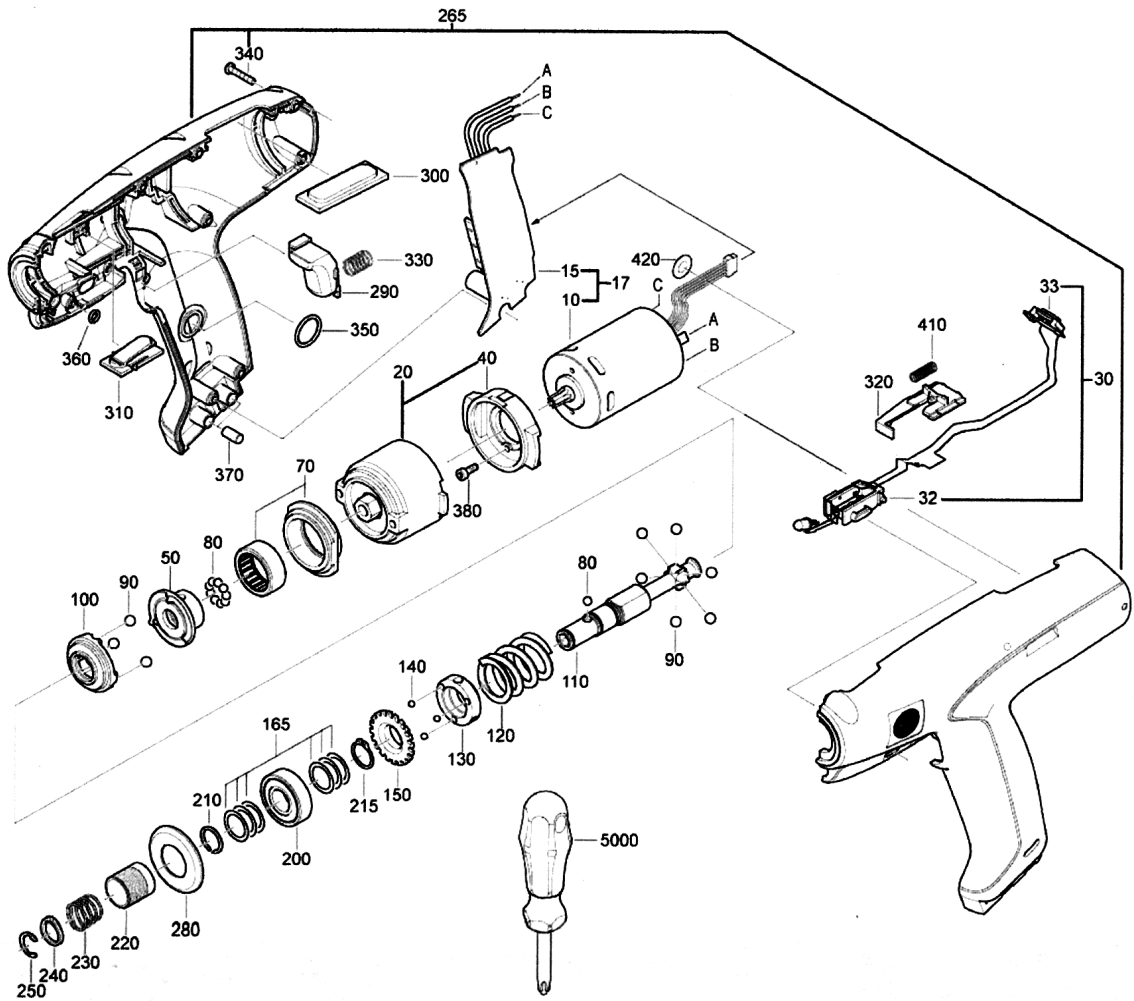

PARTS LIST — FOR REFERENCE ONLY

Index Number	Part Number	Description	Qty.	Index Number	Part Number	Description	Qty.	Index Number	Part Number	Description	Qty.
10	54199012020	Motor Assembly	1	140	41708014001	Ball	1	340	43073001000	Screw	9
15	30762268990	PC Board	1	150	32009073004	Set Collar	1	350	40612142004	Packing Ring	1
17	54199013800	EC-Motor Assembly	1	165	32408310990	Washer Set	1	360	40612127009	Packing Ring	1
20	30109173026	Planet Gear Assembly	1	200	41701010032	Groove ball bearing	1	370	31415061003	Holding Part	2
30	30762267990	Electronic Assembly	1	210	42615110009	Retainer Ring	1	380	43035117034	Fillister Head Screw	2
32	32805204002	Switch Button	1	220	30503154000	Sleeve	1	410	30901370000	Pressure Spring	1
33	30240264009	LED-Housing	1	230	30901315002	Pressure Spring	1	420	42402016990	Disc	1
40	32436070001	Motor Flange	1	240	32601242005	Ring	1	5000	32123002006	Torque Adjusting Device	1
50	30103051001	Cam Ring	1	250	42615081002	Retainer Ring	1				
70	30508040010	Bush	1	265	31912070030	Motor Housing Assembly	1				
80	41708017002	Ball	10	280	30501345020	Coding Sleeve	1				
90	41708018000	Ball	9	290	32805203004	Switch lever	1				
100	30103050002	Valve Lever	1	300	32414115000	Insert	1				
110	30104135008	Tool Holder	1	310	32424025004	Cover	1				
120	30901367004	Pressure Spring	1	320	32805207000	Switch Lever	1				
130	32009074002	Thrust Collar	1	330	30901357005	Pressure Spring	1				



10000 SE PINE ST.
 PORTLAND, OR 97216
 503-254-6600
 FAX 503-255-2615

When ordering spare parts, please specify
 tool type, part number and description.

AIMCO also offers a complete line of standard & special
 adapters, bits, sockets and extensions.

REVISED 11/06